



## BLIND HINGED DOOR

General Information	
description	hinged, revolving door
type	C00DSG2
manufacturer	Blu Bud srl
Application	
fire properties	C Class fire resistant
drawing number	C00DSG2
Size	
max horizontal clear opening (LNO)	2500 mm ( diameter 2500 mm)
max vertical clear opening (LNV)	*
horizontal cut in bulkhead (TFO)	LNO + 200 mm
vertical cut in bulkhead (TFV)	LNV + 600 mm
sill	- mm
*this dimension may change according to customer requirements	
Frame	
section shape	see dwg
section size	see dwg
thickness of steel	1 mm
materials	steel or stainless steel (ss)
finishing	raw, paint, brushed or polished (ss)
counter frame thickness	0,8mm
Leaf	
concept	sandwich
thickness	40 mm
core	one layer of mineral wool
material of skins	steel or stainless steel (ss)
coating	raw, laminates, PVC, brushed or polished (ss)
leaf frame	paint, brushed or polished (ss)
Accessories	
standard	carrier, sill cover
extra	window
Mechanical and physical properties	
noise reduction	n.a.

Product data sheet

C\_hinged\_revolving door

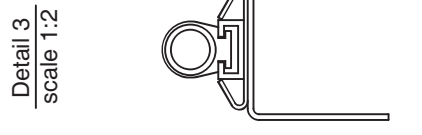
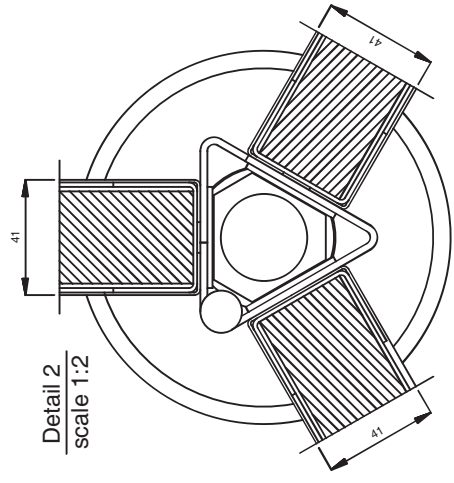
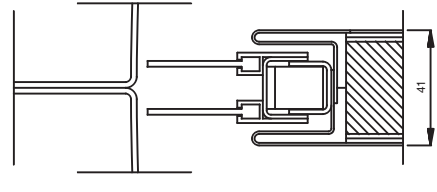
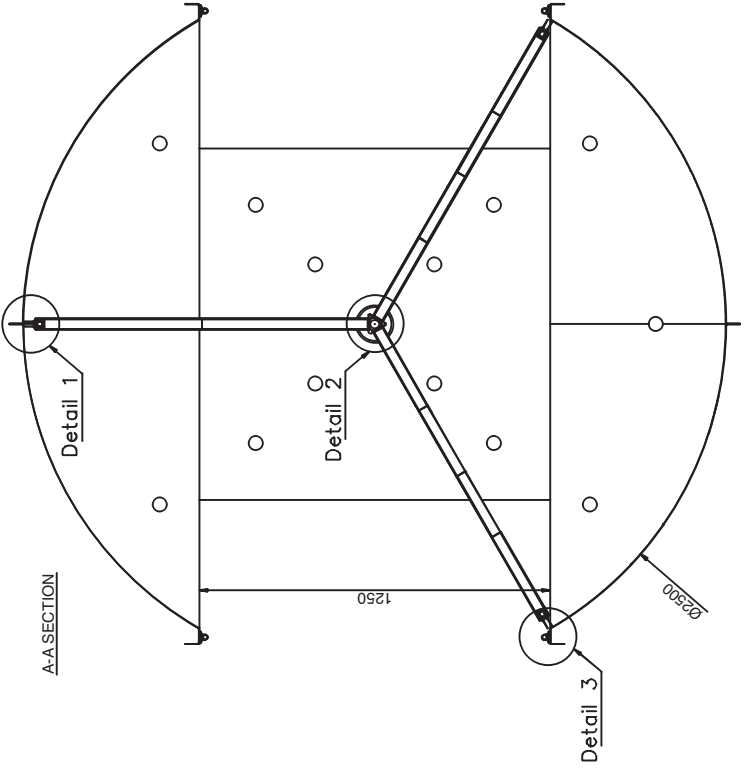
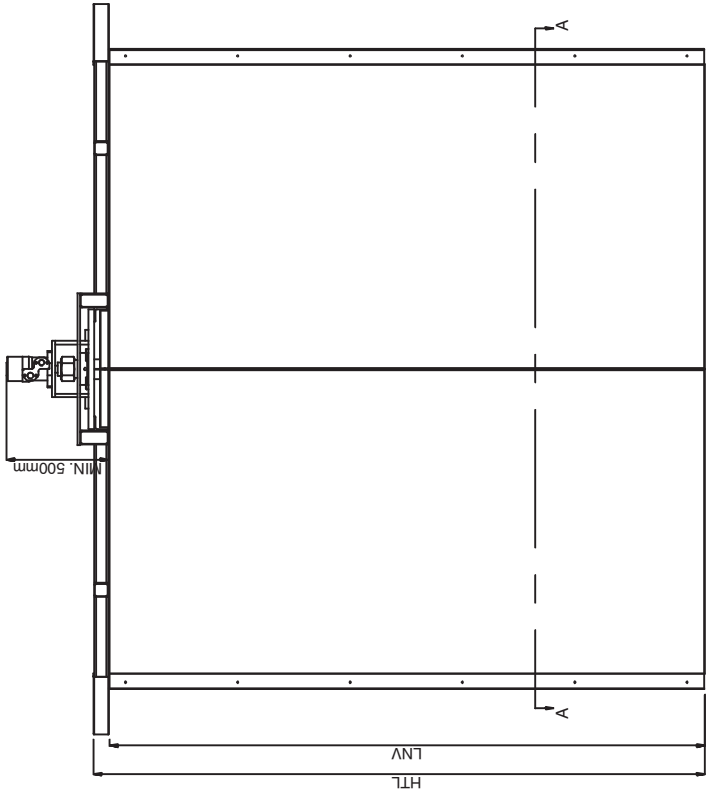

REV.	DATA / DATE	DESCRIZIONE DELLE MODIFICHE / DESCRIPTION OF ALTERATIONS	Controllato / Modified
			Checked / Revised
Codice prodotto / Product Code: C00DSG2			
Descrizione / Description: BLIND HINGED DOOR - REVOLVING			
Materiale / Material -		BLUBUD srl	
Spessore / Thickness -		Sede operativa: Via Dante 27 Tel. +39-010 89.95.59/56/98 Fax. +39-010 89.95.53/7	
Note		Sede legale: Via Fieschi 20/9 16121 Genova, Italy e-mail: info@blubud.it www: http://www.blubud.it	
Tolleranza generale / General tolerance		Scala / Scale: 1:20	
Assem		Controllato da / Checked by: R.V.	
		Disegnato da / Drawn by: M.D.S.	
		Classe prodotto / Typology: C	
		Data / Date: 24-01-12	
		Dis n. / Dwg n.: C00DSG2/1	



Questo disegno non può essere usato o riprodotto senza nostra autorizzazione  
This drawing cannot be copied, duplicated or disclosed without our permission

LATERAL VIEW

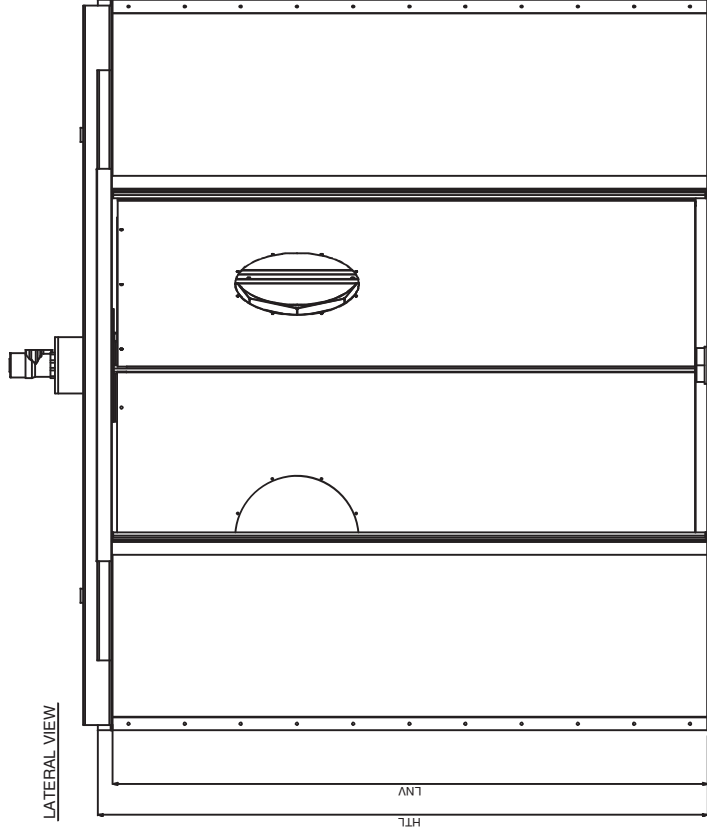

3D VIEW

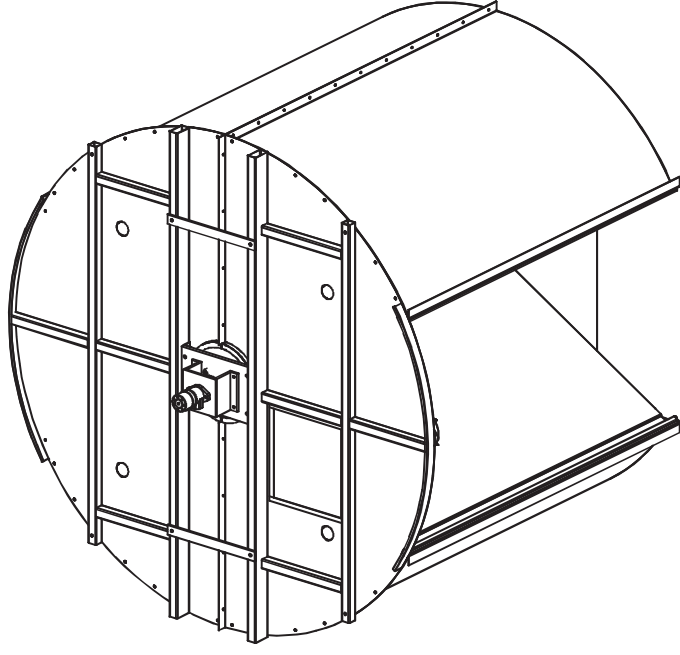

DOWN VIEW

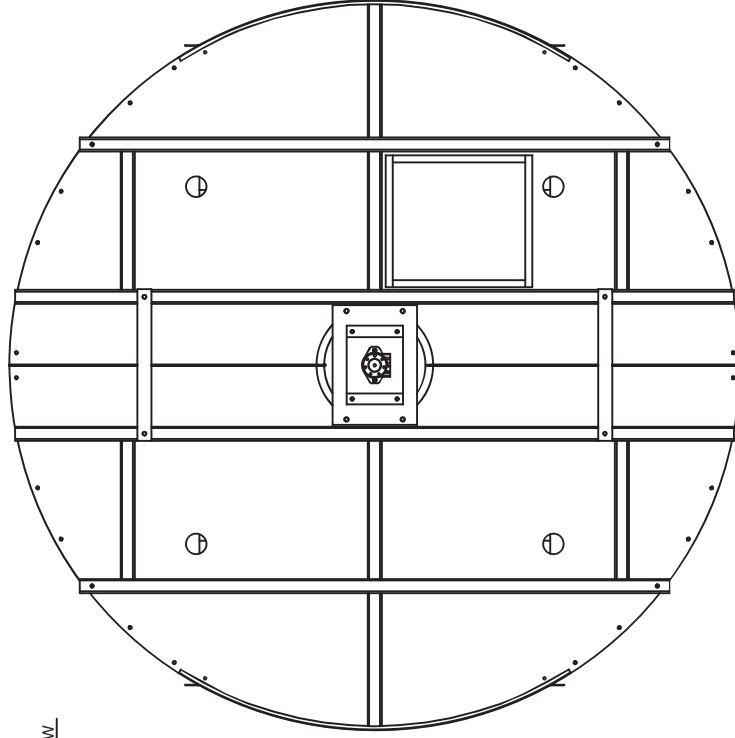

REV.	DATA / DATE	DESCRIZIONE DELLE MODIFICHE / DESCRIPTION OF ALTERATIONS	Controllato / Modified
			Checked / Revised
Codice Prodotto / Product Code		C00DSG2	
Descrizione / Description		BLIND HINGED DOOR - REVOLVING	
Materiale / Material	BLUBUD srl		Scala / Scale
Spessore / Thickness	Sede operativa: Via Dante 27 Tel. +39-010 89.85.59/56.98 Fax. +39-010 89.85.53.7		1:20
Note / Notes	Sede legale: Via Fieschi 20/9 16121 Genova, Italy e-mail: info@blubud.it www: http://www.blubud.it		Controllato da / Drawn by
Tolleranza generale / General tolerance	Peso netto / Kg Net Weight / Kg		R.V.
			M.D.S.
	Assem	Classe prodotto / Typology	C
		Dis n. / Dwg n.	C00DSG2/2

Questo disegno non può essere usato o riprodotto senza nostra autorizzazione  
This drawing cannot be copied, duplicated or disclosed without our permission